

1 2 3 4 5 6 7 8 9 10

A
B
C
D
E
F
G
H

A
B
C
D
E
F
G
H

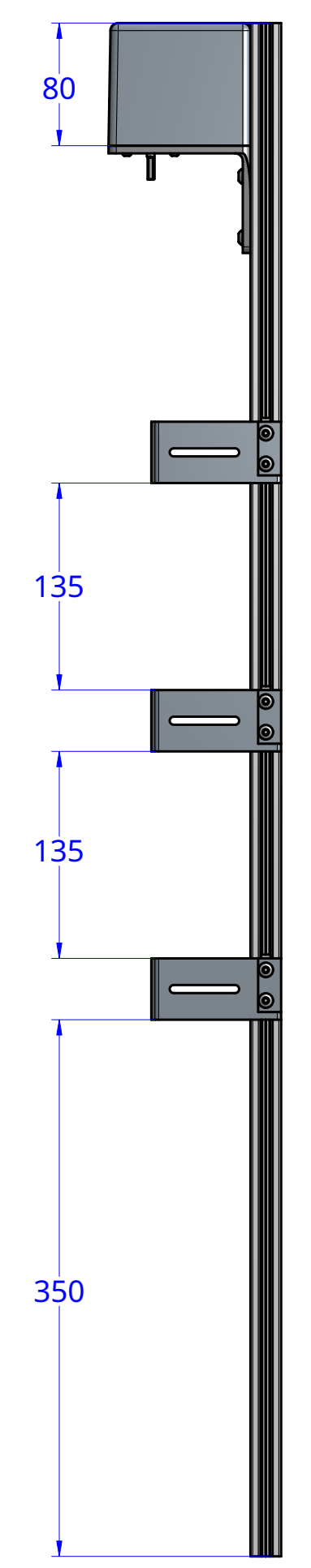
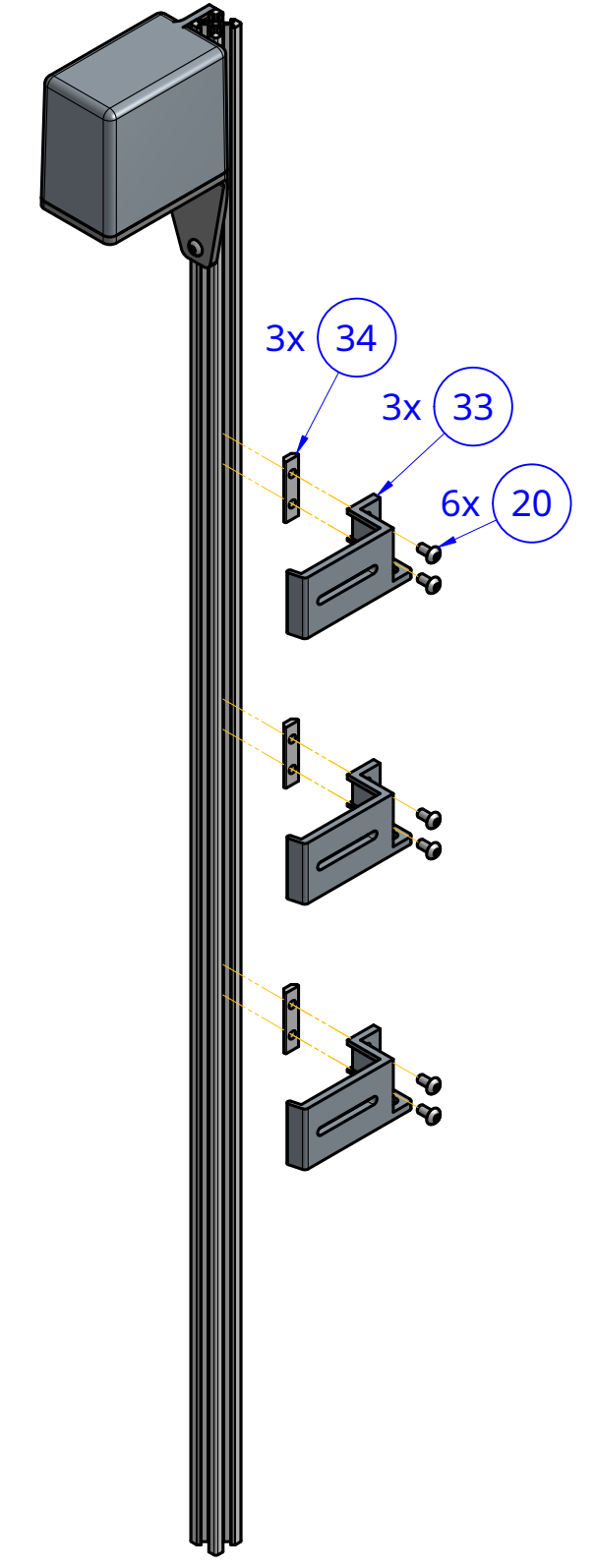
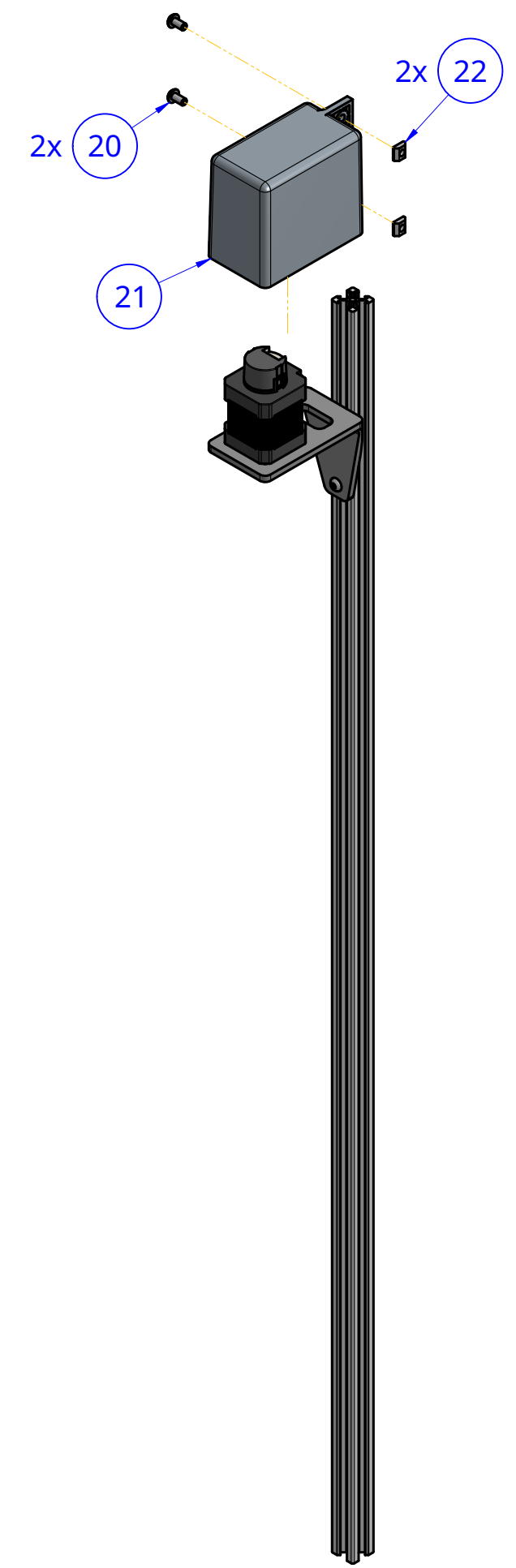
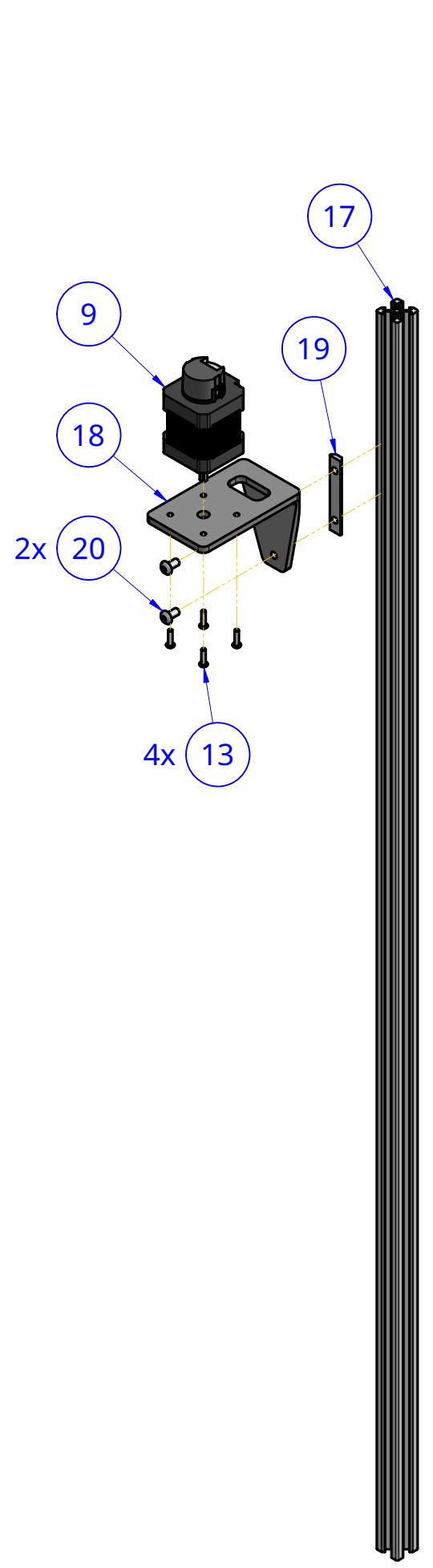

Pre-Assembled Z-Axis Rev B		
NOTES: N/A		
DRAWN BY: Rory Aronson, 2023-08-23	PROJECTION: First Angle	SHEET: 1 of 7
COMPANY: FarmBot Inc	UNITS: Millimeters	SIZE: A3
LICENSE: CC0 Public Domain Dedication	SCALE: 1:4	

1 2 3 4 5 6 7 8 9 10

1 2 3 4 5 6 7 8 9 10

A

B

C

D

E

F

G

H

A

B

C

D

E

F

G

H

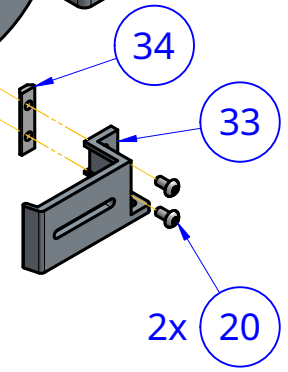
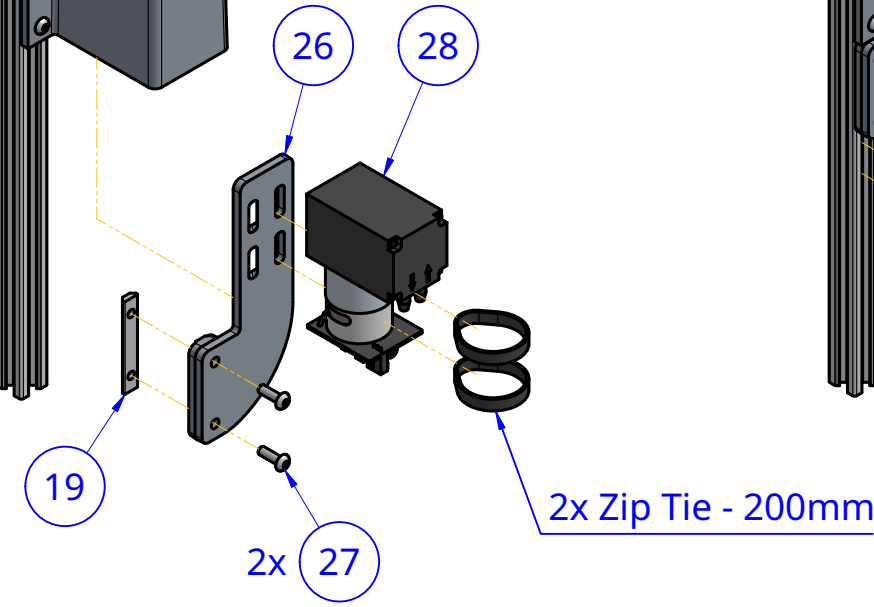
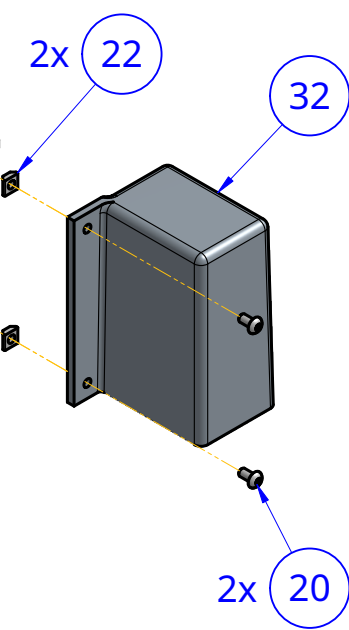
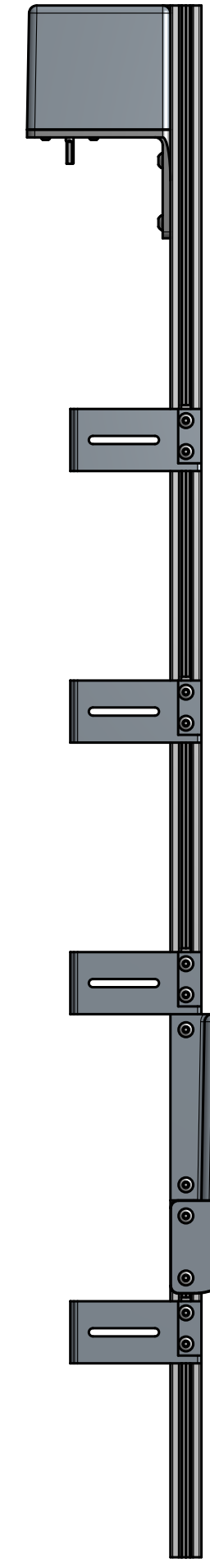
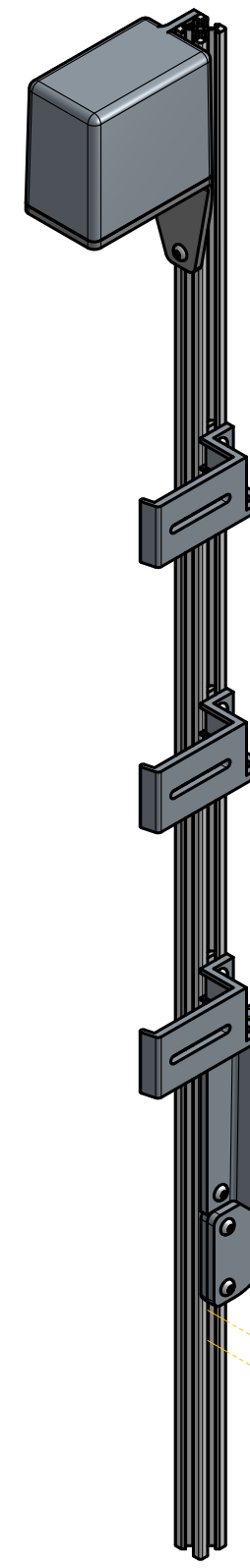
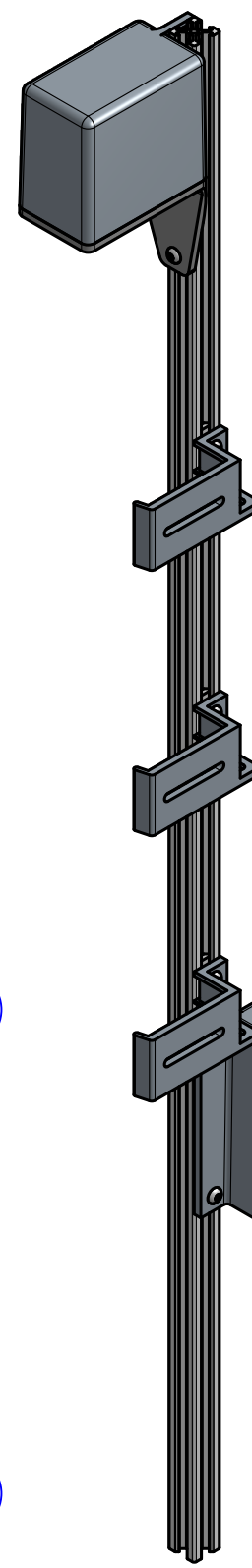
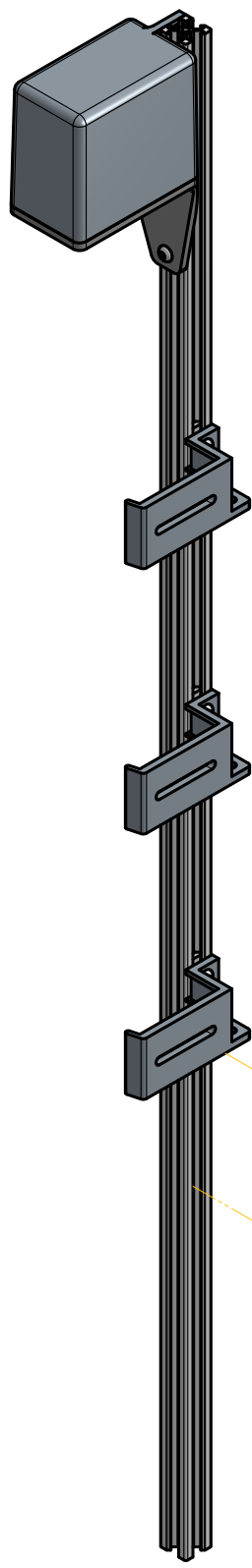

Pre-Assembled Z-Axis Rev B			
NOTES: N/A			
DRAWN BY: Rory Aronson, 2023-08-23	PROJECTION: First Angle		SHEET: 2 of 7
COMPANY: FarmBot Inc.	UNITS: Millimeters		SIZE: A3
LICENSE: CC0 Public Domain Dedication		SCALE: 1:4	

1 2 3 4 5 6 7 8 9 10

1 2 3 4 5 6 7 8 9 10

A

B

C

D

E

F

G

H

A

B

C

D

E

F

G

H

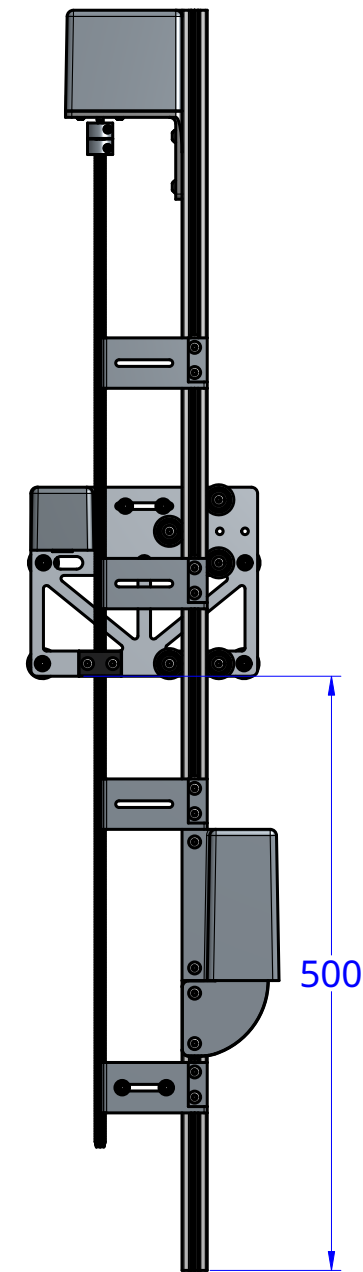
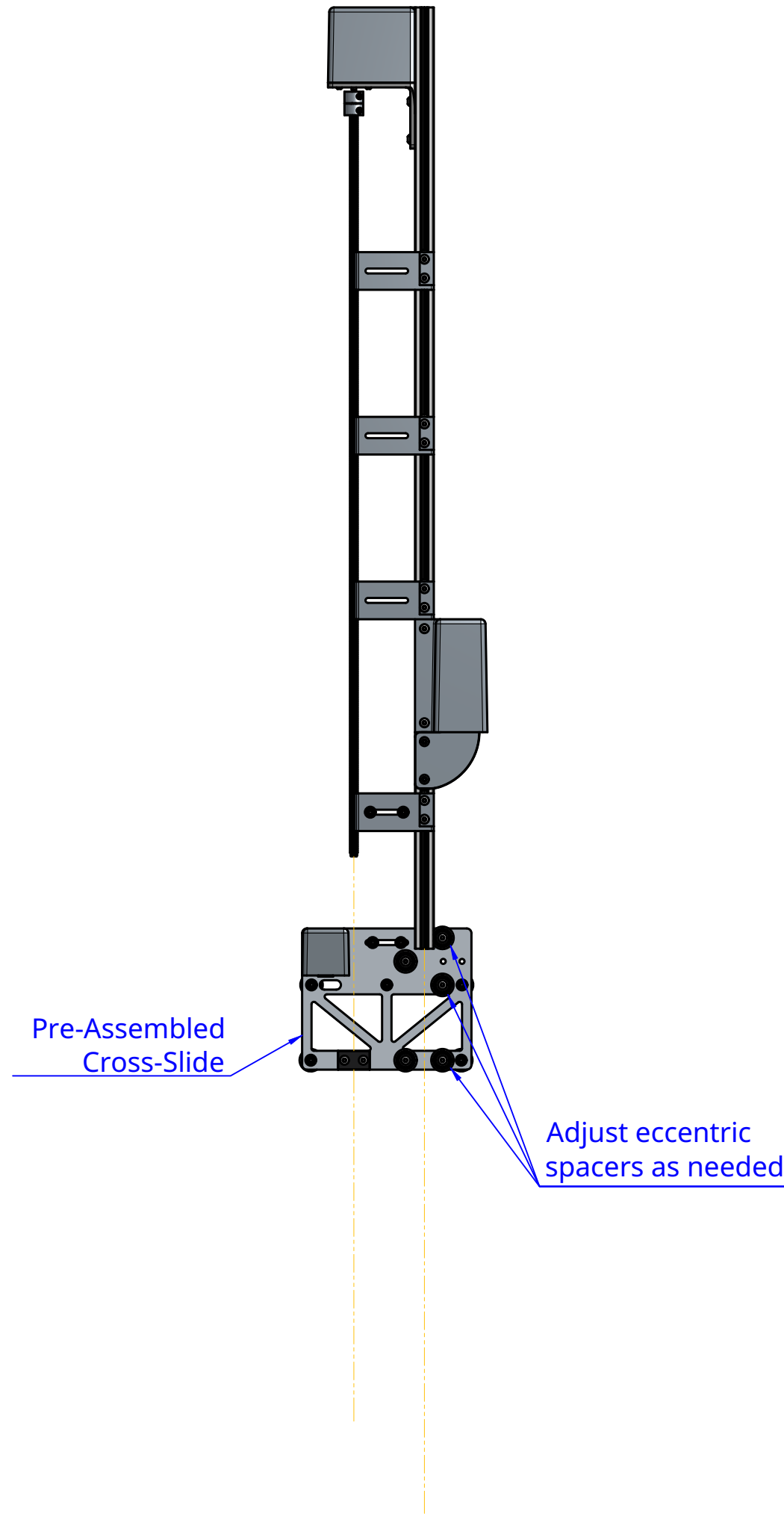
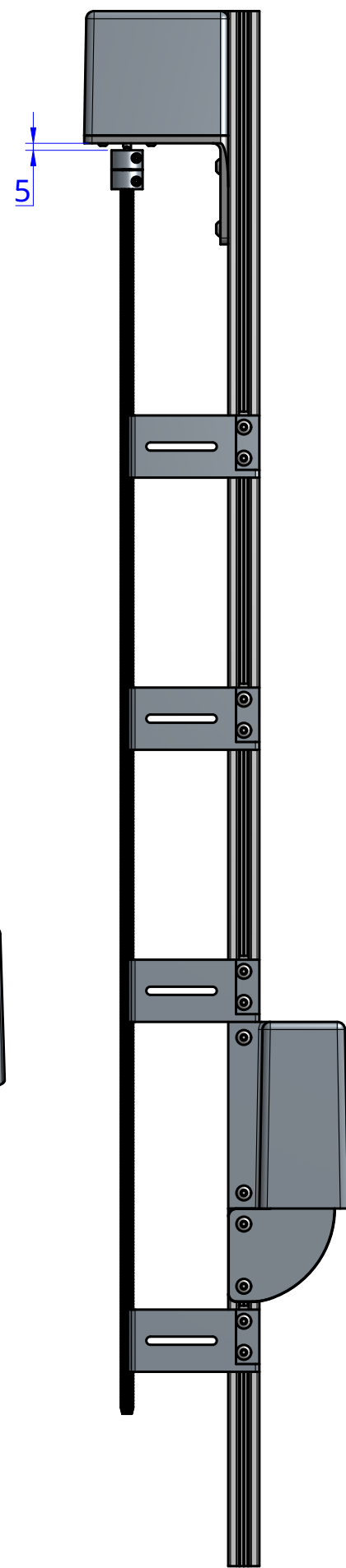
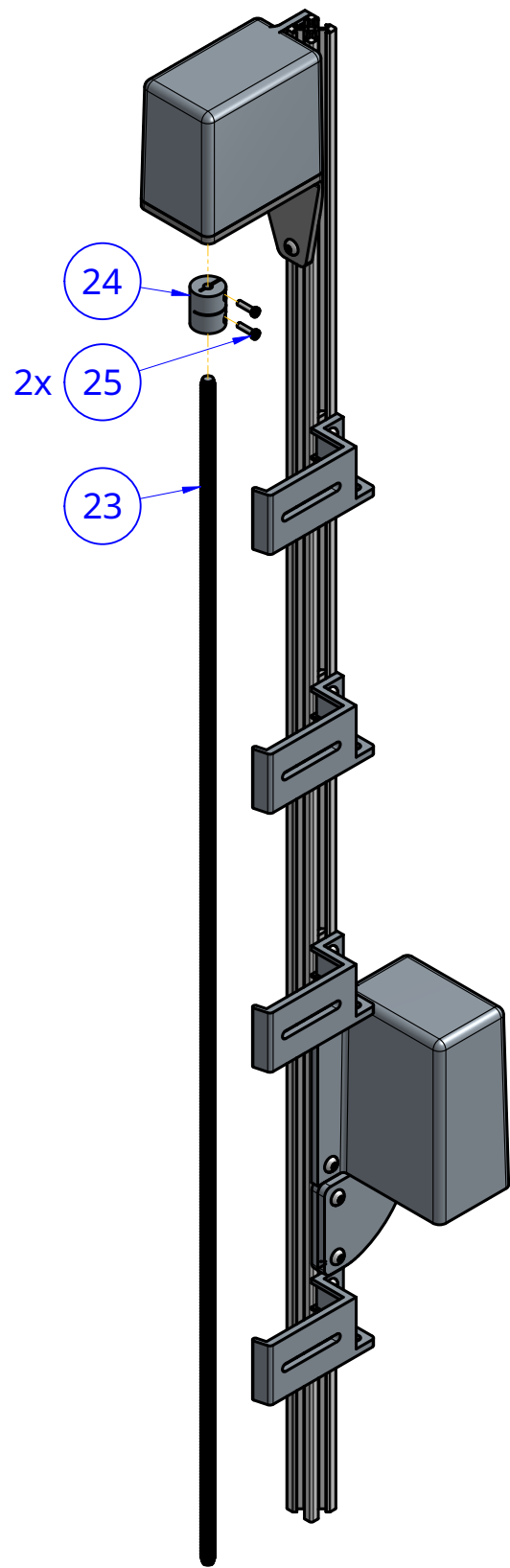

Pre-Assembled Z-Axis Rev B			
NOTES: N/A			
DRAWN BY: Rory Aronson, 2023-08-23	PROJECTION: First Angle		SHEET: 3 of 7
COMPANY: FarmBot Inc	UNITS: Millimeters		SIZE: A3
LICENSE: CC0 Public Domain Dedication	SCALE: 1:4		

1 2 3 4 5 6 7 8 9 10

1 2 3 4 5 6 7 8 9 10

A B C D E F G H

A B C D E F G H

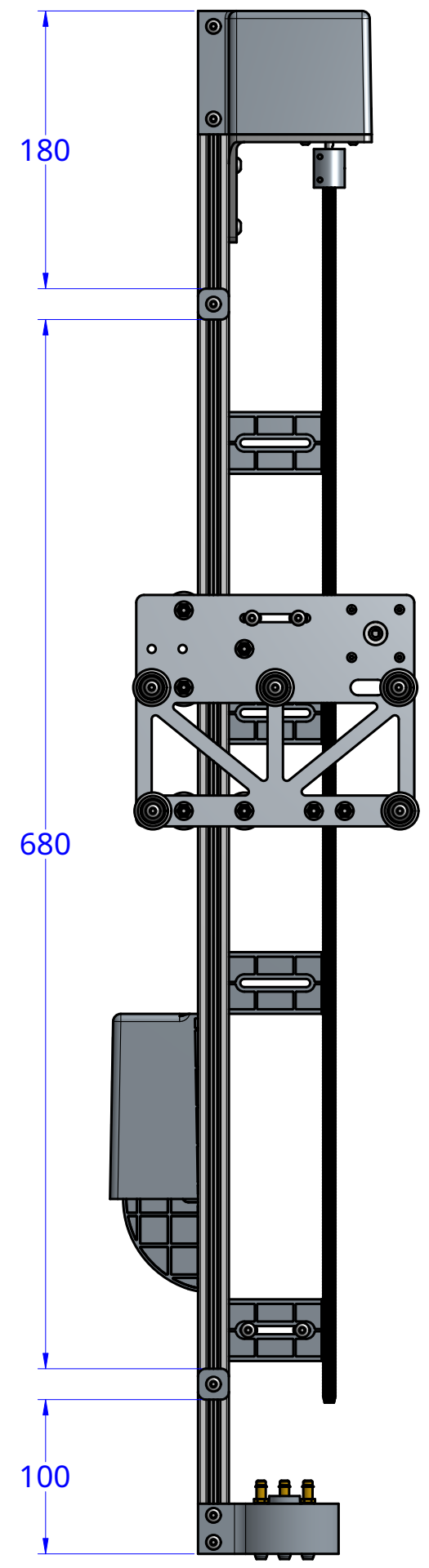
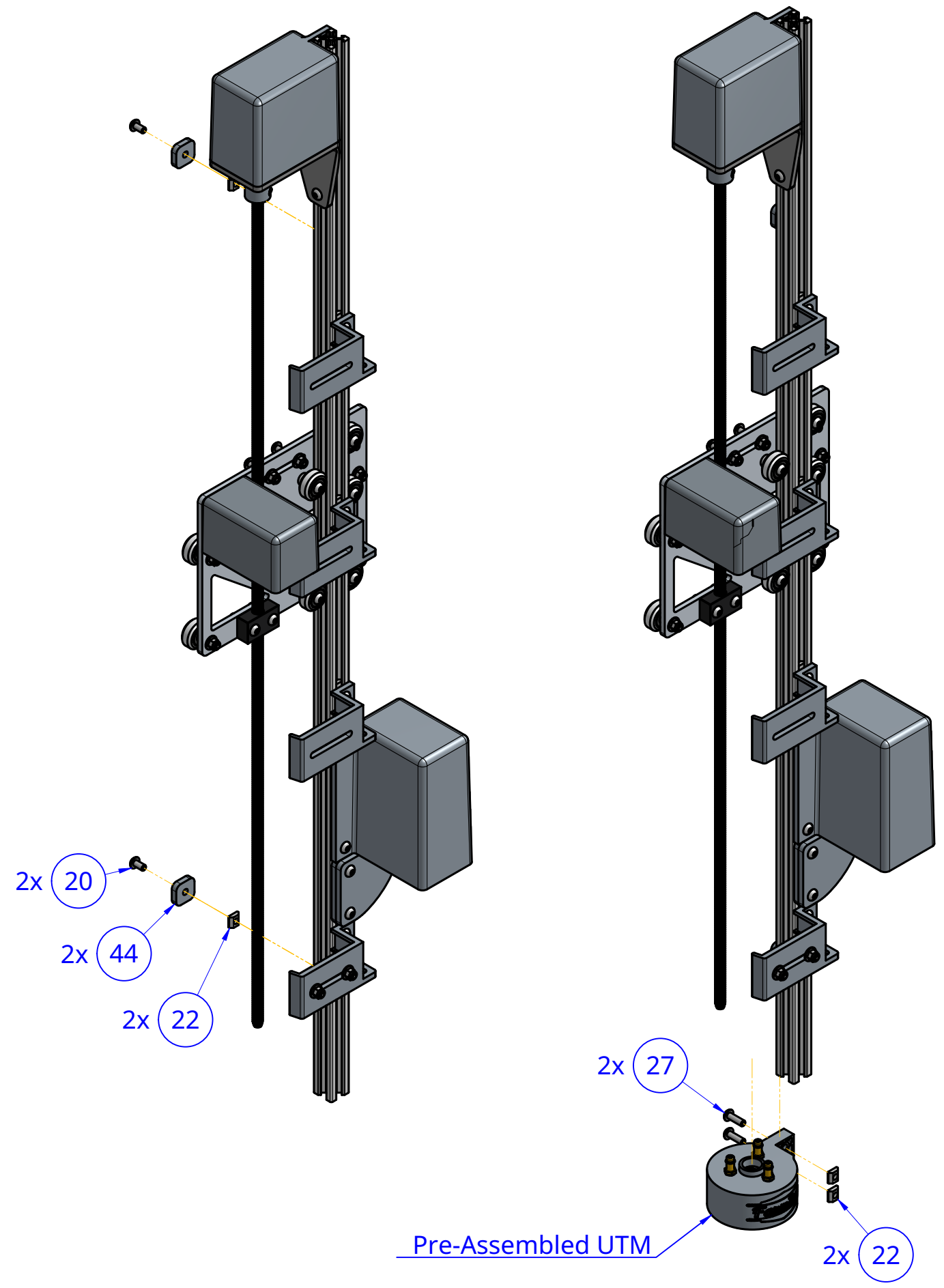

Pre-Assembled Z-Axis Rev B		
NOTES: N/A		
DRAWN BY: Rory Aronson, 2023-08-23	PROJECTION: First Angle	SHEET: 4 of 7
COMPANY: FarmBot Inc.	UNITS: Millimeters	SIZE: A3
LICENSE: CC0 Public Domain Dedication	SCALE: 1:4	

1 2 3 4 5 6 7 8 9 10

1 2 3 4 5 6 7 8 9 10

A

A

B

B

C

C

D

D

E

E

F

F

G

G

H

H

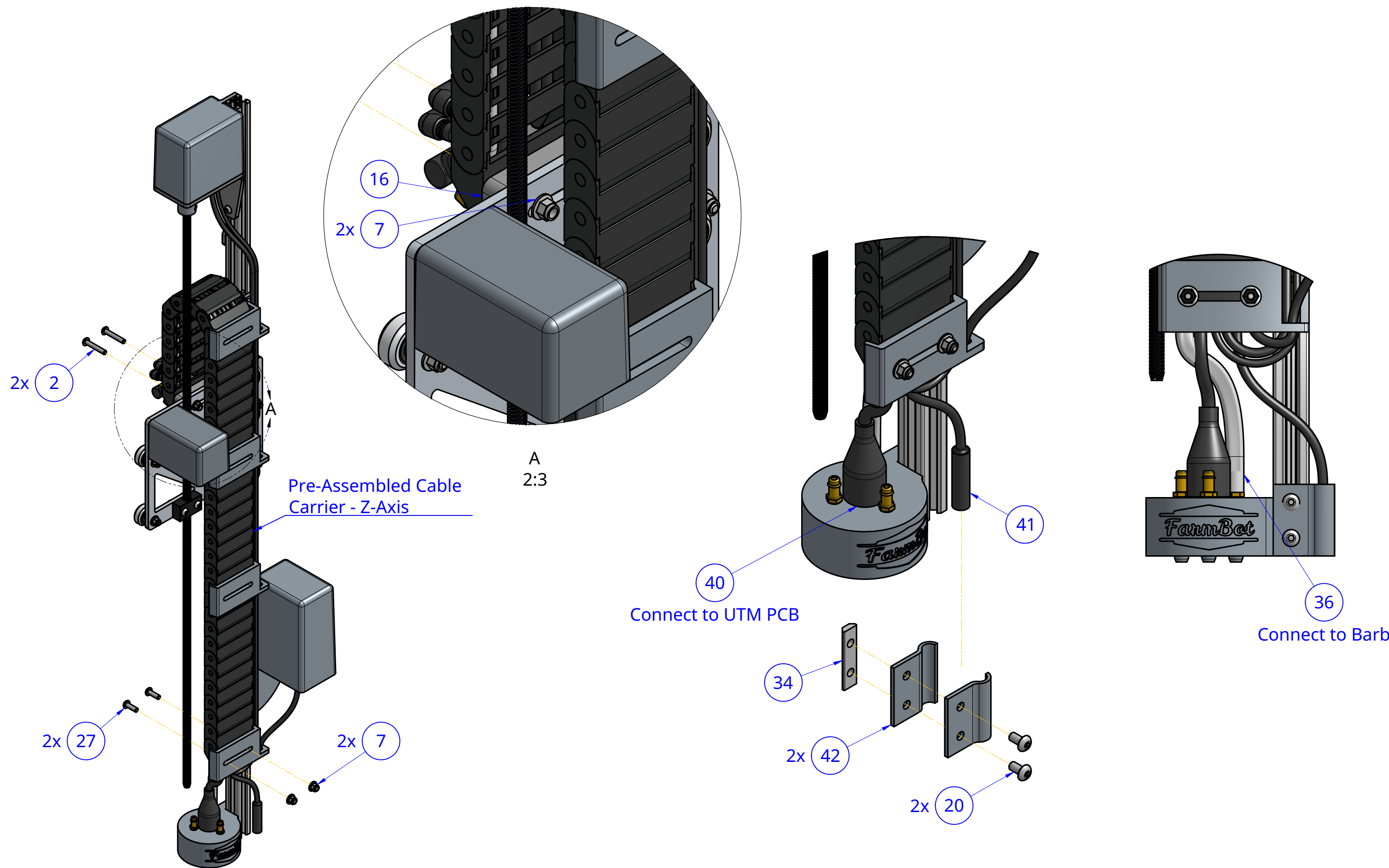

Pre-Assembled Z-Axis Rev B		
NOTES: N/A		
DRAWN BY: Rory Aronson, 2023-08-23	PROJECTION: First Angle	SHEET: 5 of 7
COMPANY: FarmBot Inc.	UNITS: Millimeters	SIZE: A3
LICENSE: CC0 Public Domain Dedication	SCALE: 1:4	

1 2 3 4 5 6 7 8 9 10

1 2 3 4 5 6 7 8 9 10

A

B

C

D

E

F

G

H

A

B

C

D

E

F

G

H

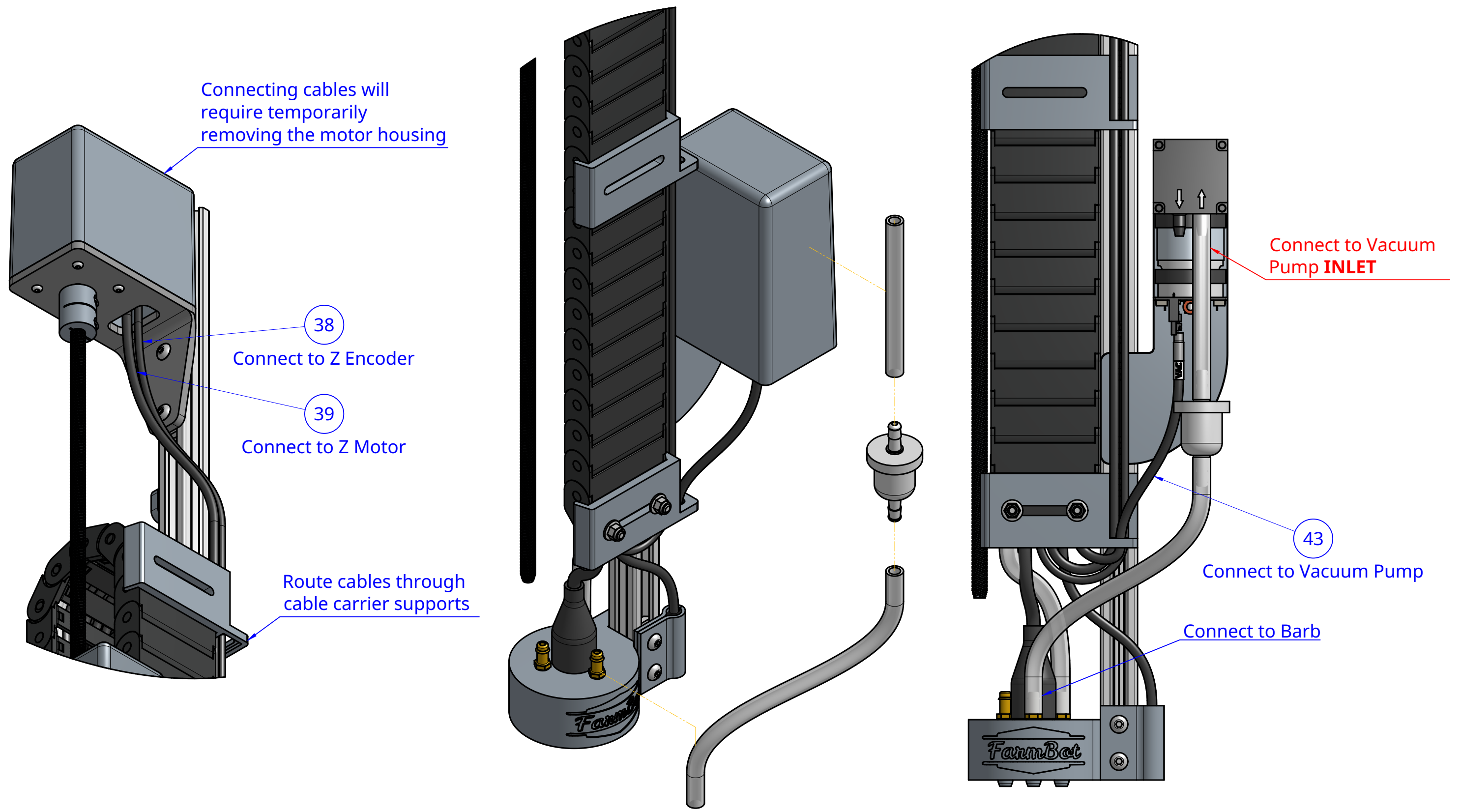

Pre-Assembled Z-Axis Rev B			
NOTES: N/A			
DRAWN BY: Rory Aronson, 2023-08-23	PROJECTION: First Angle		SHEET: 6 of 7
COMPANY: FarmBot Inc	UNITS: Millimeters		SIZE: A3
LICENSE: CC0 Public Domain Dedication	SCALE: 1:2		

1 2 3 4 5 6 7 8 9 10

	1	2	3	4	5	6	7	8	9	10			
A	Item	Internal Part Name			Rev	Quantity	Item	Internal Part Name			Rev	Quantity	A
	1	Genesis Cross-Slide Plate			C	1	31	Zip Tie - 200mm				2	
	2	M5 x 30mm Screw				12	32	Vacuum Pump Housing			A	1	
	3	V-Wheel			A	10	33	Cable Carrier Support - Vertical, 60mm			A	4	
	4	Bearing - SS-625-2RS			A	20	34	Nut Bar - 40mm			A	5	
	5	M5 x 1mm Precision Shim			A	10	35	Cable Carrier - 15 x 50 x 740mm (37 links + end pieces in Z configuration)				1	
	6	M5 x 6mm Spacer			A	5	36	6 x 10mm Tube - 0.95m (Water, Z-axis, all bots)				1	
B	7	M5 Flange Locknut				16	37	90 Degree Barb - Brass			A	1	B
	8	M5 x 6mm Eccentric Spacer			A	5	38	Encoder Cable - ZZ, 1.8m (Genesis and Genesis XL)			A	1	
	9	NEMA 17 Stepper Motor				2	39	Motor Cable - ZZ, 1.8m (Genesis and Genesis XL)			A	1	
	10	GT2 Pulley (20 Tooth)			A	1	40	UTM Cable - Z, 1.0m (Genesis and Genesis XL)			A	1	
	11	SS Setscrews w/ 2mm drive				2	41	Camera			C	1	
	12	Motor Housing - Horizontal, 75mm			A	1	42	Camera Mount Half			A	2	
C	13	M3 x 12mm Screw				8	43	Vacuum Pump Cable - Z, 1.0m (Genesis and Genesis XL)			C	1	C
	14	Leadscrew Block			B	1	44	Z-Axis Hardstop			A	2	
	15	M5 x 25mm Screw				2	45	UTM			B	1	
	16	Cable Carrier Spacer Block - 60mm			A	1	46	M5 Barb			A	3	
	17	Extrusion - 20mm x 20mm x 1000mm (Z-Axis)			N/A	1	47	UTM PCB			A	1	
	18	Genesis Z-Axis Motor Mount			D	1	48	Pogo Pin				12	
D	19	Nut Bar - 60mm			B	2	49	Pogo Pin Jam Nut				24	D
	20	M5 x 10mm Screw				18	50	Ring Magnet - Standard			A	3	
	21	Motor Housing - Vertical, 80mm			A	1	51	O-Ring - X Profile				3	
	22	Nut Bar - 10mm			A	8							
	23	Leadscrew - 8mm x 800mm				1							
	24	Shaft Coupler - 5mm to 8mm			A	1							
	25	M3 x 12mm Low-Profile Socket Head Screw				2							
E	26	Vacuum Pump Mount			B	1							E
	27	M5 x 16mm Screw				9							
	28	Vacuum Pump - 24V with EMI Filter			1.1	1							
	29	Inline Air Filter (Barbs for 6mm ID tubing)				1							
	30	6 x 10mm Tube - 0.15m (Vacuum)				2							
F												F	
G												G	
H												H	
	1	2	3	4	5	6	7	8	9	10			

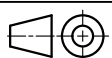
Pre-Assembled Z-Axis Rev B			
NOTES: N/A			
DRAWN BY: Rory Aronson, 2023-08-23	PROJECTION: First Angle		SHEET: 7 of 7
COMPANY: FarmBot Inc	UNITS: Millimeters		SIZE: A3
LICENSE: CC0 Public Domain Dedication		SCALE:	