

1 2 3 4 5 6 7 8 9 10

A B C D E F G H

Item	Internal Part Name	Rev	Quantity
1	Watering Nozzle Top	A	1
2	Watering Nozzle Bottom	A	1
3	15 x 5 x 5mm Ring Magnet		3
4	M5 x 30mm Screw		3
5	M5 Flange Locknut		3
6	Jumper Link	A	1
7	M3 x 12mm Screw		2
8	M3 Locknut		2

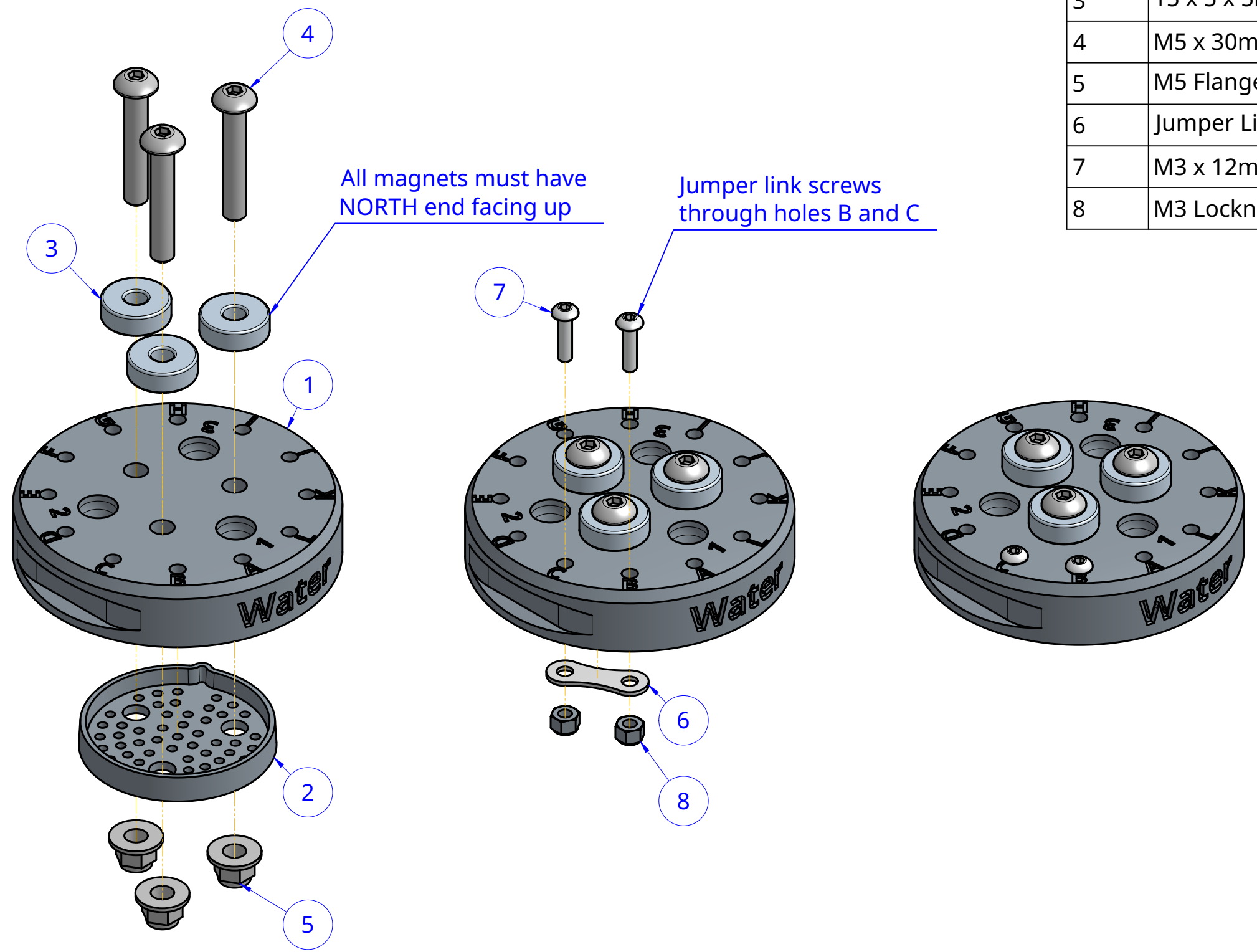

Pre-Assembled Watering Nozzle Rev A

NOTES:

DRAWN BY: Rory, 2021-10-06  
 COMPANY: FarmBot Inc  
 LICENSE: CC0 Public Domain Dedication

PROJECTION: First Angle  
 UNITS: Millimeters  
 SCALE: 1:1

SHEET: 1 of 2  
 SIZE: A3

1 2 3 4 5 6 7 8 9 10